

IN-DUCT AIR QUALITY DETECTOR— PMD SERIES



Specification Data



FEATURES

- PMD-18 in-duct air quality detector is specially designed for monitoring multi-parameter air quality in air duct, Which is installed in wind duct or return air duct.
- Built-in a large air bearing fan, regulate the fan speed automatically, guarantee constant air volume and improve the stability and lifetime in long-term working.
- Special design of pitot tube, instead the air pump mode, adapt to a wider range of wind speeds. To have longer lifetime and no need to change the air pump frequently.
- Easy to clean filter mesh, can be disassembled and used many times.
- With temperature and humidity compensation, reduce the impact of environmental change.
- Real-time monitoring parameters: particles (PM2.5 and PM10), carbon dioxide (CO₂), TVOC, air temperature and humidity, as well as optional carbon monoxide and formaldehyde/ozone,.
- Independently measure the temperature and humidity in the air duct, avoid interference from other sensors and monitoring heating.
- Provides WIFI, RJ45 Ethernet, RS485 Modbus communication interfaces selection. Provide multiple communication protocol choices.
- Connect to the data acquisition/analysis software platform to achieve data storage, data comparison and data analysis.
- Data can be read and displayed on-site with blue tooth or the operation tool.
- Working with MSD indoor air quality monitors together, comprehensively and accurately analyze the air quality. Quantitative assessment of indoor air pollution.
- Approved by CE, RESET, RoHS, FCC, REACH and ICES.

APPLICATION

- Online real-time detecting indoor air quality.
- Green Building Assessment
- BAS and HVAC
- Smart Home System
- Fresh Air Controlling System
- Building Energy Saving Reconstruction and Assessment System
- Classroom, office, exhibition hall, shopping mall, other public place

TECHNICAL SPECIFICATIONS

General Data

Power Supply	12-28VDC/18-27VAC or 100-240VAC (optional)
Communication Interface:	Choose one in the following
a. RS485 RTU	9600bps (default), 15KV Antistatic Protection.
b. RJ45 (Ethernet TCP)	MQTT protocol or Modbus TCP optional With an extra RS485
c. WiFi@2.4 GHz 802.11b/g/n	MQTT protocol or Modbus TCP optional With an extra RS485
Data upload interval cycle	Average / 60 seconds
Applicable air speed of duct	2.0~15m/s
Working Condition	-20 °C-60 °C(-4 °F-140 °F)/ 0~99%RH, (No condensation)
Storage Condition	0 °C~50 °C(32 °F-122 °F) / 10~60%RH
Overall Dimension	180X125X65.5mm (7.09X4.92X2.58in)
Pitot tube size	240mm (9.45in)
Net weight	850g (1.87lb)
Shell material	PC material

CO2 Data

Sensor	Non-Dispersive Infrared Detector (NDIR)
Measuring Range	0-2,000ppm
Output Resolution	1ppm
Accuracy	±50ppm + 3% of reading or ±75ppm (whichever is bigger)

Particle Data

Sensor	Laser particle sensor
Measuring Range	PM2.5: 0-500ug/m3 PM10: 0-1000ug/m3
Output values	moving average/60 seconds, moving average/1 hour, moving average/24 hours
Output Resolution	0.1ug/m3
Zero Point Stability	<2.5ug/m3
Accuracy	PM2.5: 8% of reading (10%-80%RH,@25°C) PM10: 12% of reading (0-500µg/m3, 10%-80%RH,@25°C)

Temp & Humidity Data

Sensor	Band gap material temperature sensor、Capacitive humidity sensor
Temperature range	-20°C-60°C
Relative humidity range	0-99%RH
Output Resolution	Temperature: 0.01°C humidity:0.01%RH
Accuracy	±0.5°C@5-35°C, ±3%RH (20%-80%RH)

CO Data (Optional)

Sensor	Electrochemical CO sensor
Measuring Range	0-100ppm
Output Resolution	0.1ppm
Accuracy	±1ppm+ 5% of reading (10%-80%RH,@25°C)

Ozone Data (Optional)

Sensor	Electrochemical ozone sensor
Measuring Range	0-2000ug/m3 (0-1000ppb)
Output Resolution	1ug/m3
Accuracy	±15ug/m3+10% of reading (10%-80%RH,@25°C)

HCHO Data (Optional)

Sensor	Electrochemical formaldehyde sensor
Measuring Range	0.001-0.6mg/m3
Output Resolution	0.001mg/m3
Accuracy	±0.005mg/m3+5% of reading (10%-80%RH,@25°C)

TVOC Data

Sensor	Metal oxide sensor
Measuring Range	0.001-3.50 mg/m3
Output Resolution	0.001 mg/m3
Accuracy	±0.002mg/m3+ 15% of reading (at 0.001-1.0 mg/m3)

MODELS GUIDE

Model	PM2.5 PM10	CO2	TVOC	Temp/ RH	CO	Ozone	HCHO	Communication Interface	Extra RS485 interface
PMD-1818C/D	•	•	•	•				RS485 (Modbus RTU or BACnet MS/TP)	No
PMD-1819C/D	•	•	•	•			•		
PMD-1816C/D	•	•	•	•	•				
PMD-1816Z-C/D	•	•	•	•	•	•			
PMD-1810C/D	•	•	•	•	•		•		
PMD-1828C/D	•	•	•	•				WiFi @2.4 GHz 802.11b/g/n	Yes
PMD-1829C/D	•	•	•	•			•		
PMD-1826C/D	•	•	•	•	•				
PMD-1826Z-C/D	•	•	•	•	•	•			
PMD-1820C/D	•	•	•	•	•		•		
PMD-1838C/D	•	•	•	•				RJ45 (Ethernet TCP)	Yes
PMD-1839C/D	•	•	•	•			•		
PMD-1836C/D	•	•	•	•	•				
PMD-1836Z-C/D	•	•	•	•	•	•			
PMD-1830C/D	•	•	•	•	•		•		

C: 24VAC/VDC power supply
D: 100~240VAC power supply

Ozone and formaldehyde cannot be selected at the same time, only selected one of them.

DIMENSIONS

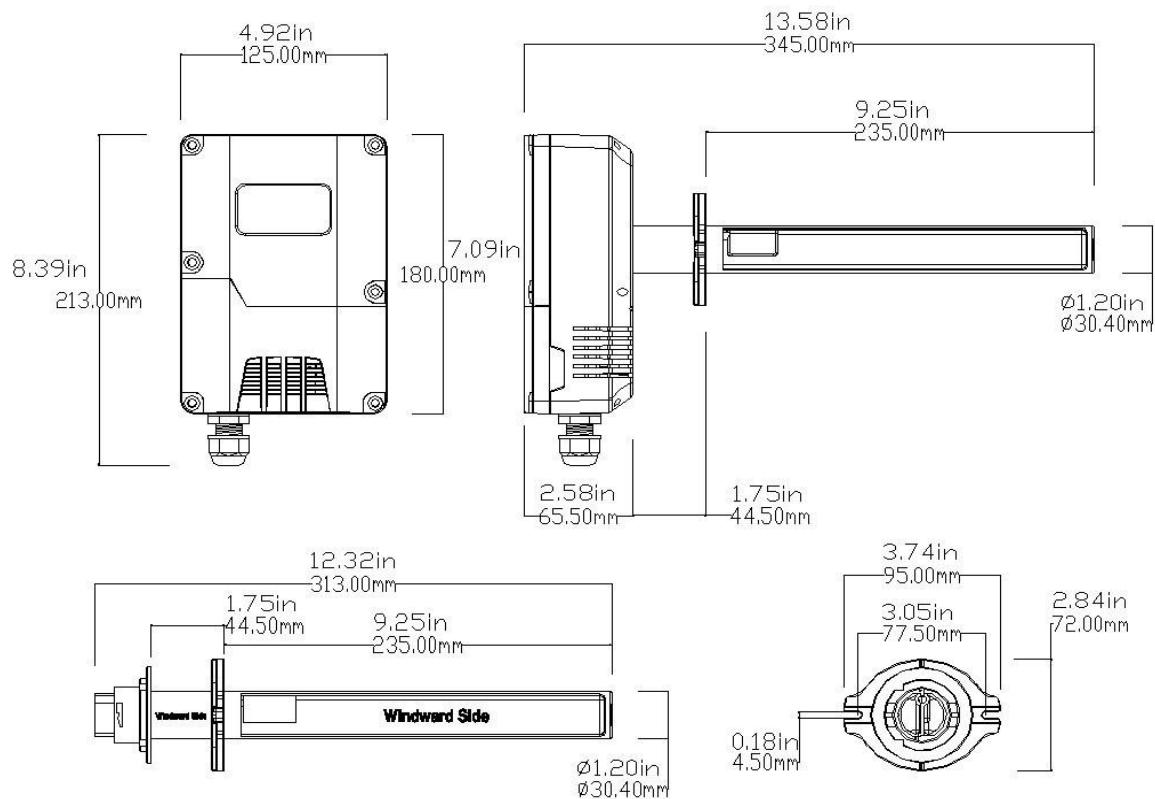

NETWORK DIAGRAM

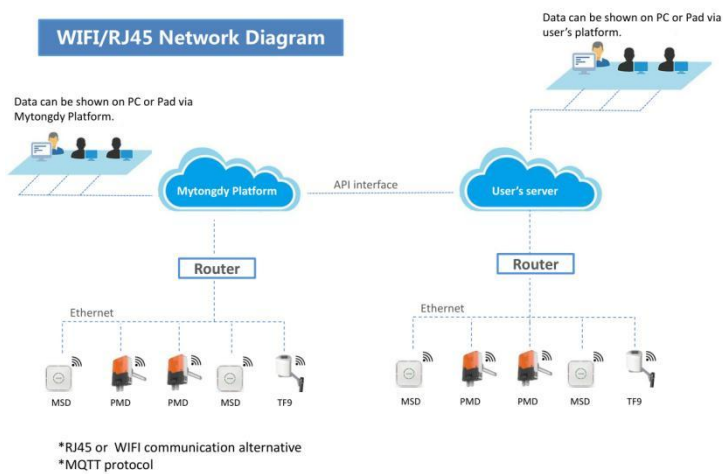

- Professional designing and manufacturing IAQ products more than 14 years, long-term exportation to global markets with powerful performances guaranteed
- Built-in commercial high-precision sensor module, with proprietary technology, long-term stable and reliable application
- Industrial grade shell and structure to satisfy different environment. Removable filter mesh for easy cleaning and reuse
- Pitot tube inlet and outlet design, instead of air pump for the long lifetime usage
- Regulate fan speed automatically to guarantee constant air volume
- Provide a variety of communication interface to select and connect a monitoring and analysis software platform, for data storage, analysis and comparison
- Optional two power supply, more convenient for installation
- RESET Certificate
- CE-Approval, FCC, ICES

